

HUB Outreach and Engagement TAMU Galveston Pier Upgrades

McCarthy Buildings Companies, Inc.
Marine Division



Meet the Team

- Jerrad Jefferson – Supplier Diversity Manager
- Chuck Shive – Preconstruction Director
- Keshav Vasudevan – Preconstruction Manager
- Diego Laris – Project Superintendent

TAMU-G Pier Improvement Supplier Diversity Plan

NSMV Ship Dock



OUTREACH

- Early Project Awareness
- Pre-Bid/Outreach
 - Information Sessions for HUB's (Opportunity Day)
 - Prime + M/WBE meetings partnering opportunities
- Other forms of advertising
 - Websites/Social Media
 - Digital Media Advertising
- Early notice of RFP Schedules (Building Connected Entry)
- *HUB* One on One Meetings upon request.

PROCUREMENT

- Competitive Bidding
- HUB assistance with bidding (Estimating Best Practices Class)
- Detailed scope & bid reviews (Pre & Post Bid)
- Develop HUB Utilization Plan for submission & approval to Texas A&M University System HUB Program
- Communicate & reinforce diversity goals and requirements

TRACKING & MONITORING

- Monthly meetings w/ HUB Program Leadership
- Workforce development goals
- HUB Goal Monitoring (Digital Platform)
 - 2ND & 3RD Tier Spend will be counted
 - Material Suppliers & Distributors will receive only 60% of Purchase Order agreement M/WBE Goal Credit.
 - Manufacturer's will receive 100% M/WBE Goal Credit
- Certified Payroll Monitoring (Digital Platform)

CERTIFICATIONS

Certification	City of Houston (OBO)	State of Texas - Tx Comptroller - TxDOT	Texas Unified Certification Program (TUCP)	Minority Supplier Development Council (MSDC)	Women's Business Enterprise Alliance (WBEA)	Tri-County Regional Black Chamber of Commerce
MBE						
WBE						
HUB	✓	✓	✓	✓	✓	✓
DBE						
SBA 8(a)	U.S. Small Business Administration (SBA) only					

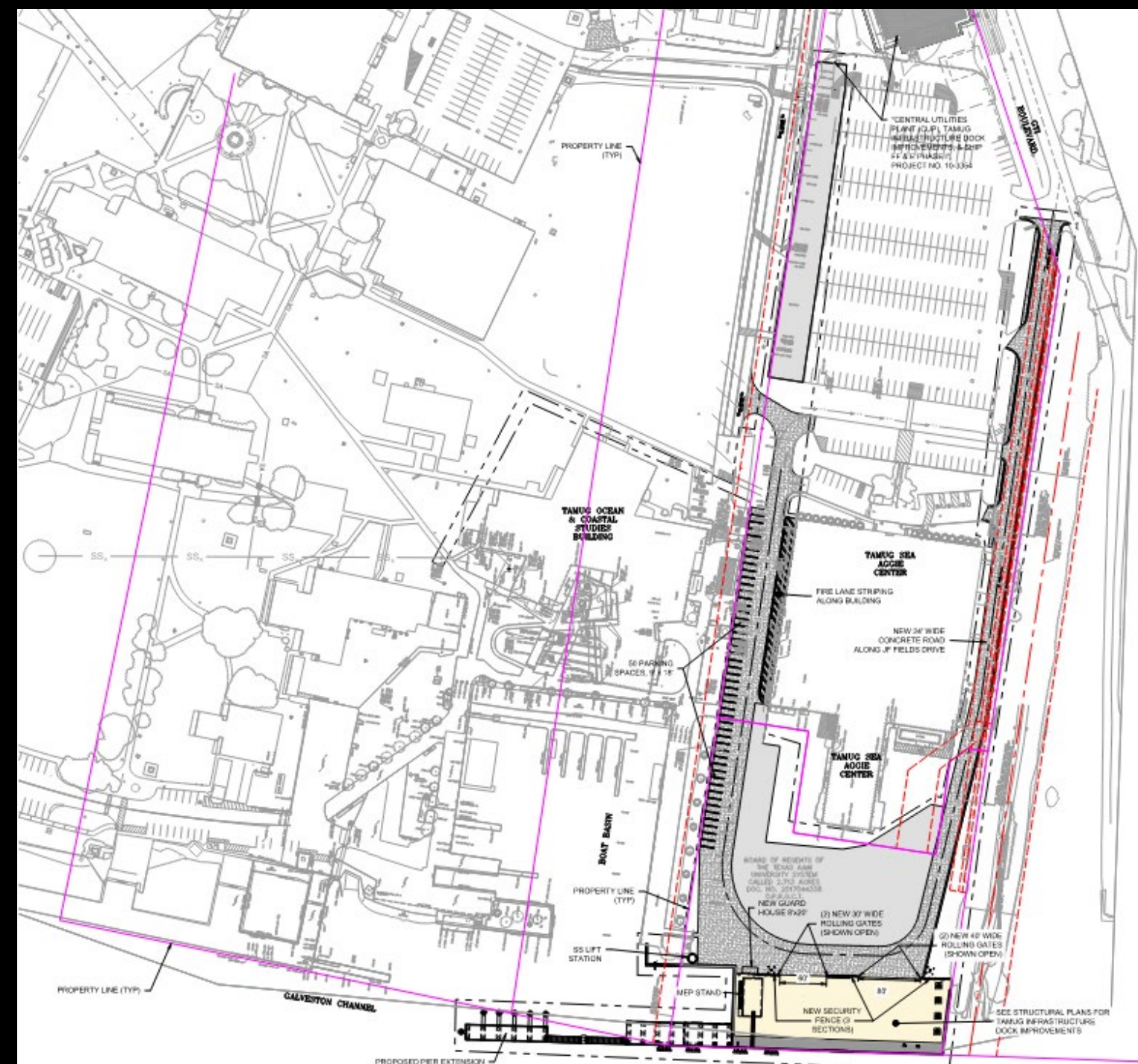

1. General Works

- SWPPP
- Traffic Control
- Survey
- Temporary Fencing & Barricading

2. Demolition Warehouses

- Concrete Foundations
- Asbestos Abatement

3. Site Improvements

- Demo and Dispose of Pavement
- Concrete Pavement
- HMAC Paving
- Fence and Gates
- Excavation
- Precast Building
- Precast Curb Stops
- Striping and Signage

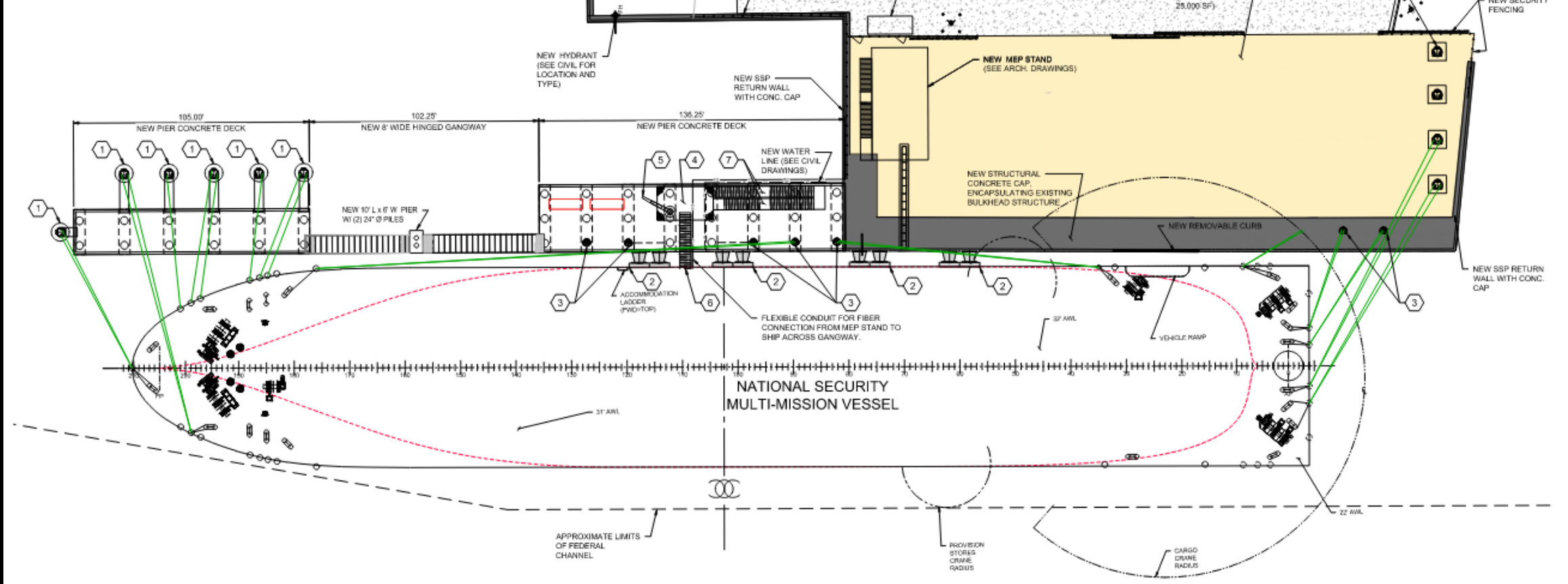

4. Marine Structures



- Pipe Piles
- Combi-Pipe Piles
- Sheet Piles
- Metal Fabrication
- Tie Rods
- Cast in Place Concrete
- Precast Concrete
- Rebar Supplier
- Rebar Installation
- Divers
- Trucking
- Soil Anchors
- Fenders
- Bollards
- Cathodic Protection
- Precast MEP Building
- Cable Trench
- Aluminum Walkways

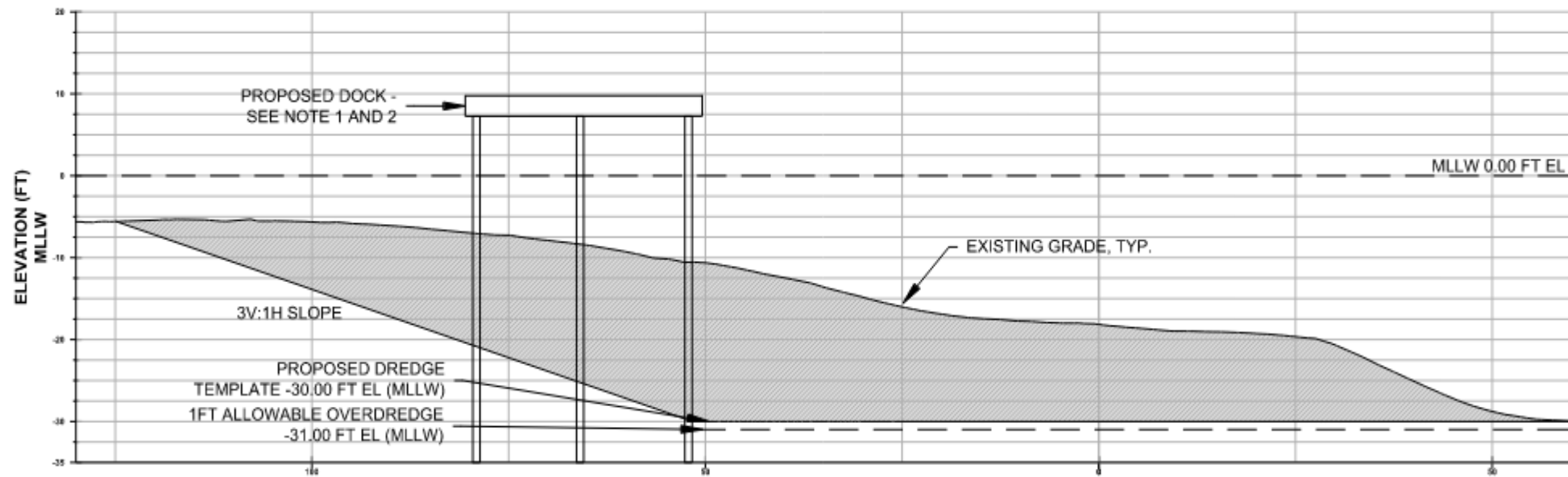

A
C-102
TYPICAL CUT- PROPOSED DREDGE AREA
DREDGE TEMPLATE PROFILE

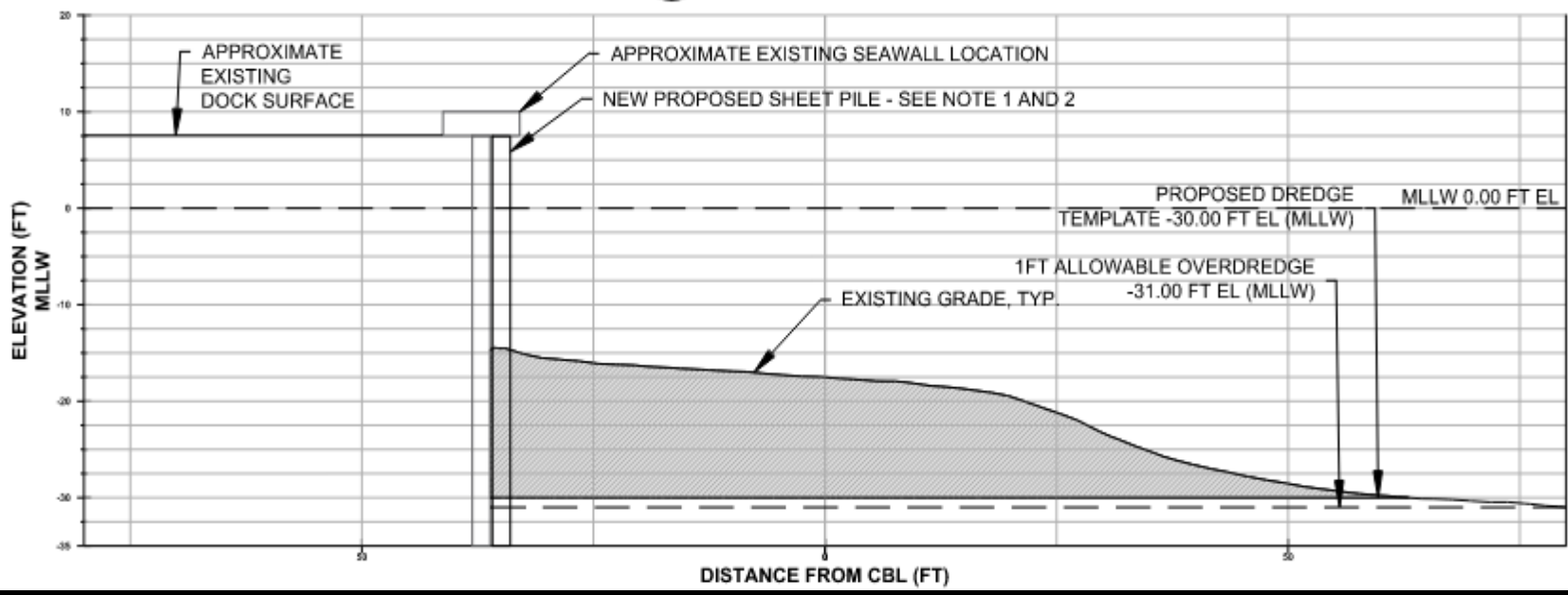

5. Dredging

Approximately
30,000 Cubic Yards

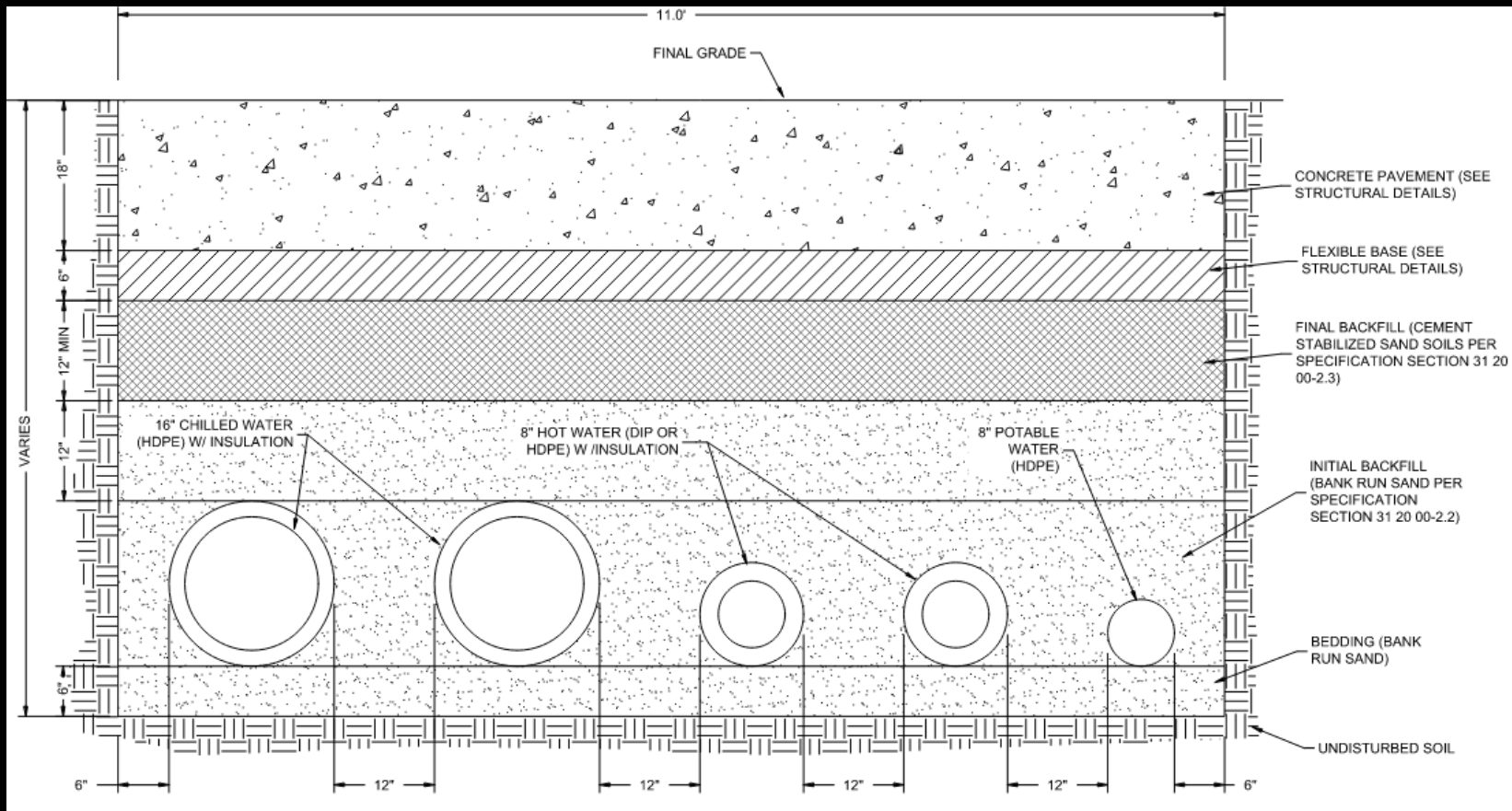

6. Utilities

Util Corridor Length: 1,200 lf

- Waterline
- Firewater
- Fire Hydrants
- San. Sewer Force Main
- San. Sewer Lift Stations
- Hydro Ex for San. Sewer Lines
- Chilled and Hot Water Lines

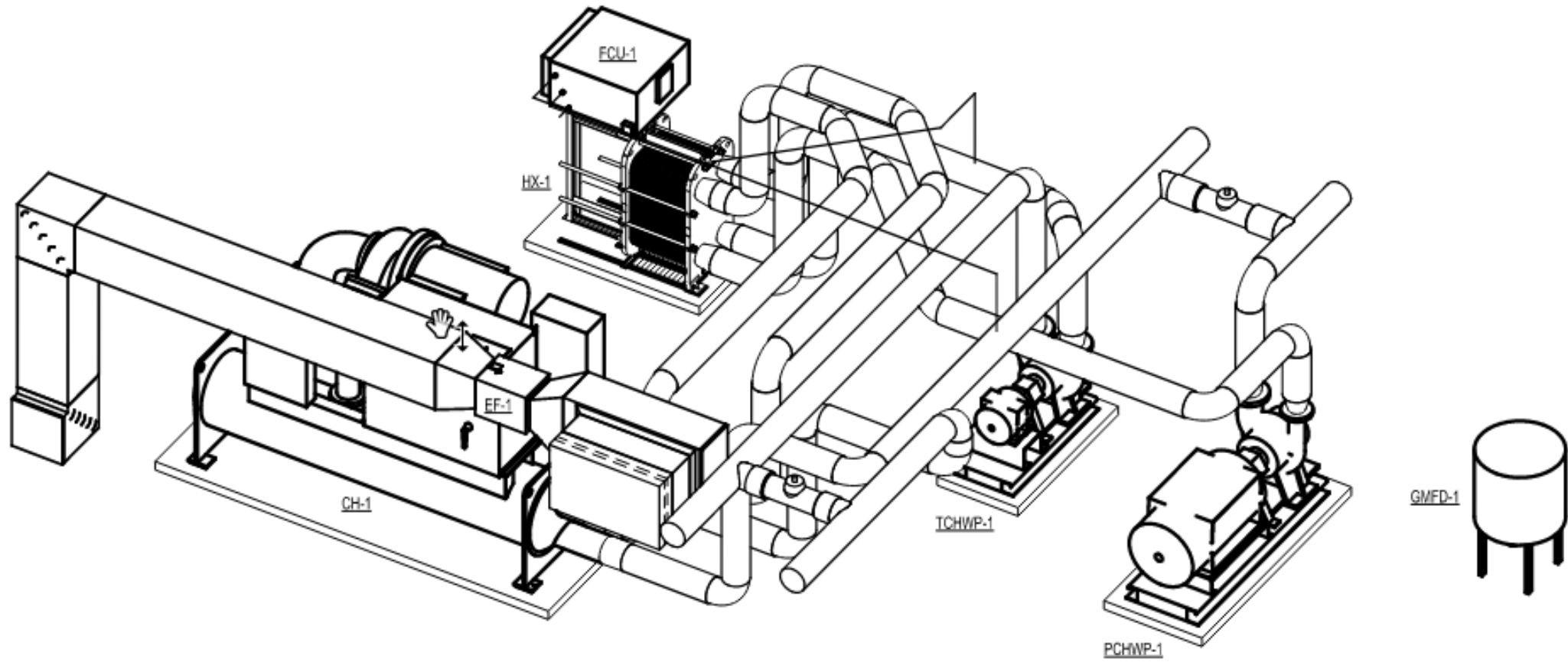

7. Mechanical

- MEP Structure
- MEP Equipment
- HVAC for MEP Building

8. Electrical and Telecommunications

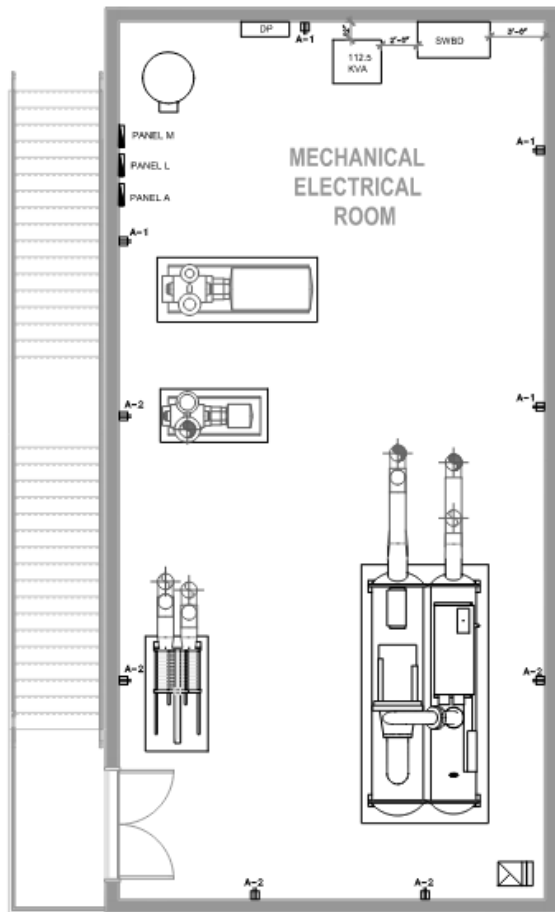

MEP STAND POWER FLOOR PLAN

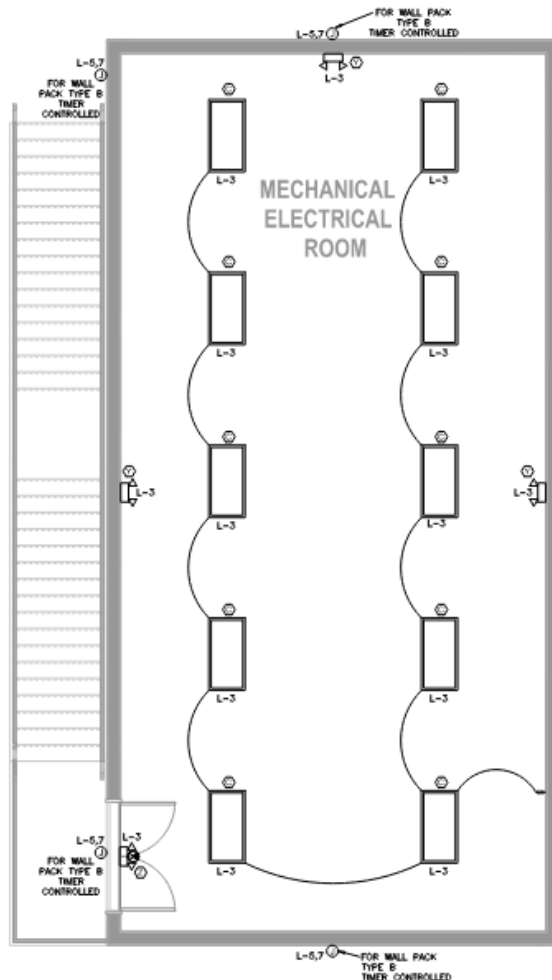

MEP STAND LIGHTING FLOOR PLAN

- Manholes
- Handholes
- Ductbank (1,500 lf)
- Loop Switches
- Site Lighting
 - HMLP
 - MEP Building Electrification
- Electrical equipment
 - Transformers
 - Switch Gear & Cabinet
 - Breakers
 - Distribution Panels
- Grounding
- Security Systems
- Telecommunications



THANK YOU

Q&A



McCarthy Prequalification System



Any questions please
contact Jackie Ramirez
jramirez@mccarthy.com

THRESHOLDS: SUBCONTRACTS



100K : 500K : 1M

Prequalification

Performance
Security

Tier 2 – Financial
Review (CDI Projects Only)

THRESHOLDS: PURCHASE ORDERS



500K : 1M : 1M

Prequalification

Performance
Security

Tier 2 – Financial
Review (CDI Projects Only)